

ENERGY BUILDER®

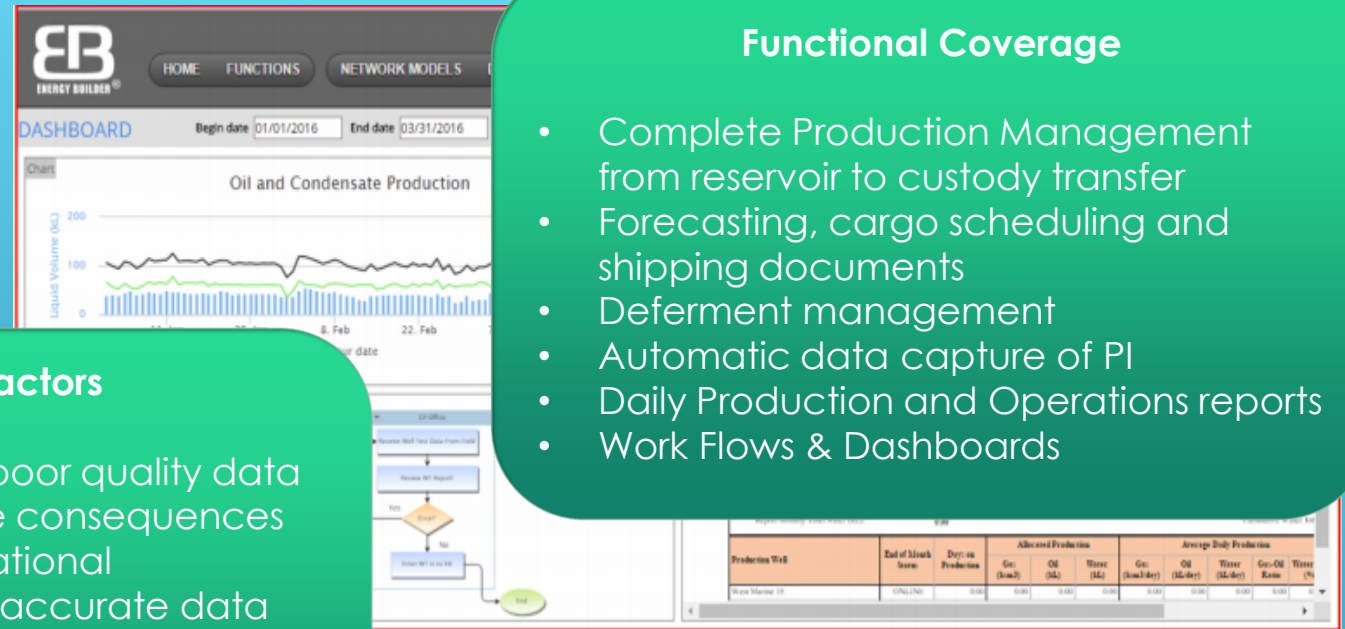

Key Driving Factors

- Early identification of poor quality data can prevent negative consequences e.g. financial or reputational
- Delivery of timely and accurate data
- Reduce human error
- Controlled and auditable process
- Measurable KPI's
- Improved decision making

Functional Coverage

- Complete Production Management from reservoir to custody transfer
- Forecasting, cargo scheduling and shipping documents
- Deferment management
- Automatic data capture of PI
- Daily Production and Operations reports
- Work Flows & Dashboards

Driving Down Costs

- No servers required – SaaS Cloud Solution
- No upfront license cost
- Rapid implementation (~12 weeks)
- Low cost implementation
- At least a 50% cost reduction from market leading vendor
- Low cost ongoing support; No Maintenance Fees

Suneses-Energy provides Hydrocarbon Accounting Solution with Energy Builder

Email: info@suneses-energy.com

Mobile: +234.08055315450

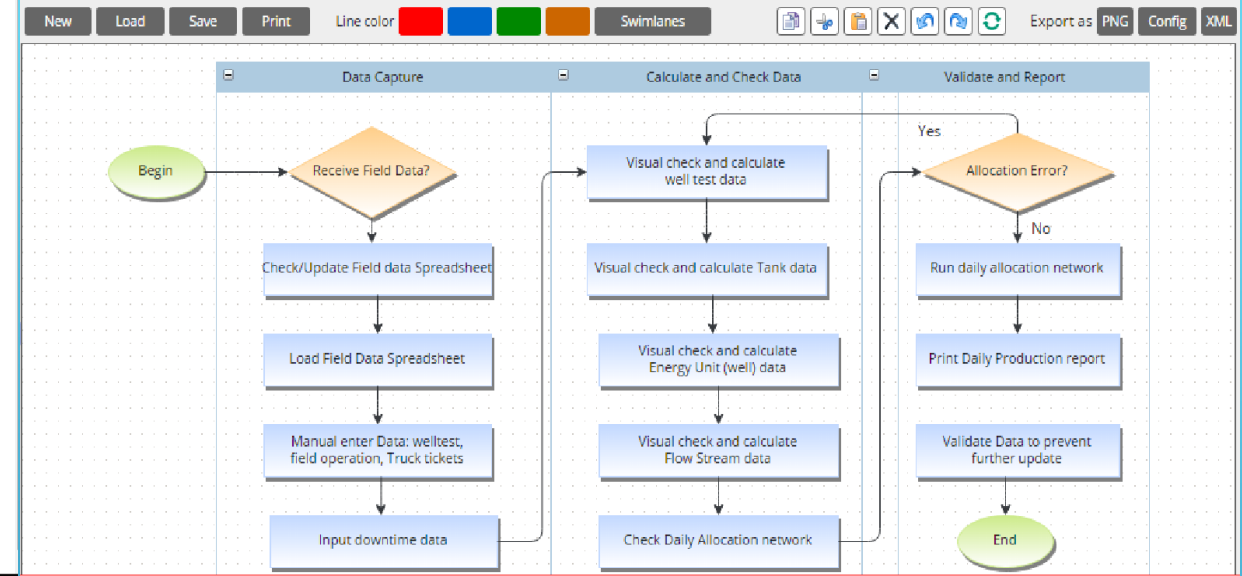
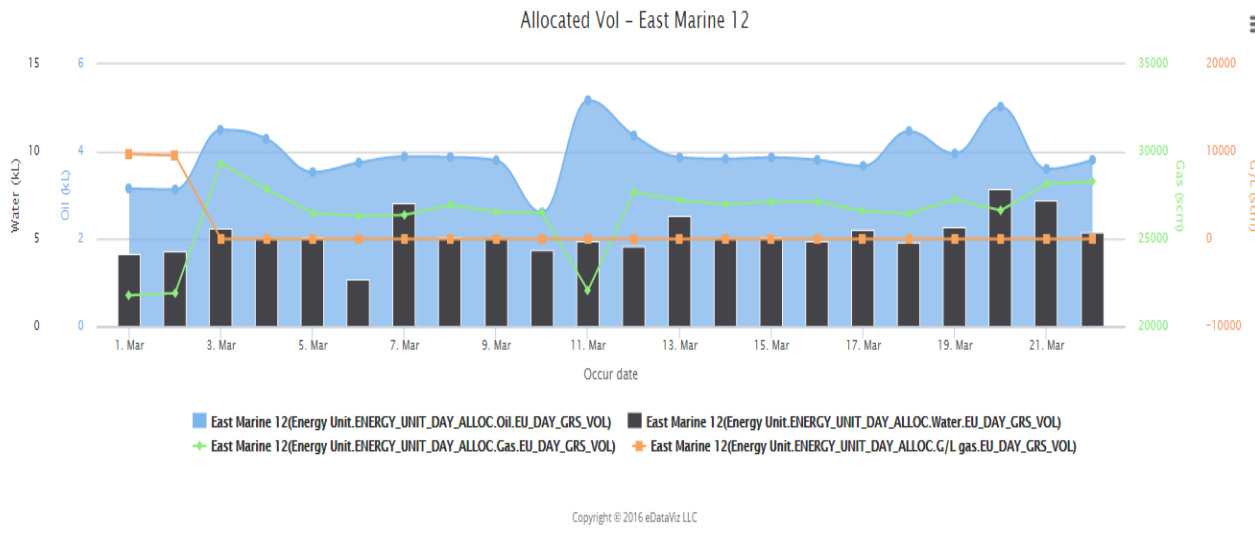

CHALLENGES	ISSUES	ENERGY BUILDER
<p>Cost</p> <p>Reduce Operational Expenditure</p>	<ul style="list-style-type: none"> License costs Maintenance costs Server costs Lengthy implementation projects Costly 3rd party contractors 	<ul style="list-style-type: none"> No up-front license fee No maintenance costs SaaS hosted in the cloud by the vendor Rapid implementations Low cost implementation partner
<p>Value</p> <p>Increase Speed and Accuracy</p>	<ul style="list-style-type: none"> Data visibility Poor data quality Resource intensive reporting Risk of human error Not ready for partner audits 	<ul style="list-style-type: none"> Built in dashboard for data visibility Automated process flows Built in reporting (rapid ad hoc reports) Data checking Auditable data
<p>Control</p> <p>Increase Flexibility & Accountability</p>	<ul style="list-style-type: none"> Lack of data accountability No data validation or approval Data integrity issues New assets require costly contractors to configure 	<ul style="list-style-type: none"> Workflow tasks assigned to users Validation & approval processes Data locking Flexible and user friendly

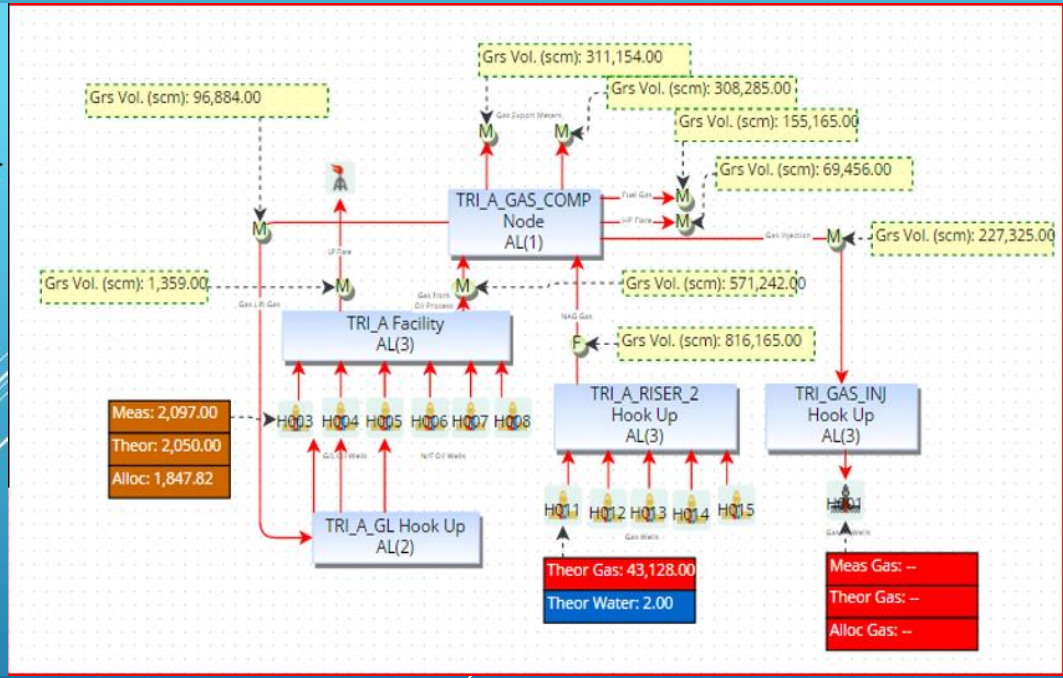

ENERGY BUILDER®

Email: info@suneses-energy.com
 Mobile: +2348055315450

